

Instruction Manual

SWA-2441B PID TEMPERATURE CONTROLLER INSTRUCTION MANUAL

Version 1.2 (Aug, 2023)



1. Caution

- This controller is intended to control equipment under normal operating conditions. If failure or malfunction of the controller may lead to abnormal operating conditions that may result in personal injury or damage to the equipment or other property, devices (limit or safety controls) or systems (alarm or supervisory) intended to warn of or protect against failure or malfunction of the controller must be incorporated into and maintained as part of the control system.
- Installing the rubber gasket supplied will protect the controller front panel from dust and water splash (IP54 rating). Additional protection is needed for higher IP rating.
- This controller carries a 90-day limited warranty. This warranty is limited to the controller only.

2. Specifications

Table 1. Specifications

Input Type	Thermocouple: K, E, J, T, S. RTD: Pt100, Cu50
Input Range	K (-20~2370°F), S (-20~2912°F), T (-190~750°F), E (-20~1290°F), J (-20~1651°F), Pt100 (-200~1100°F) Cu50 (-56~302)
Display	Two lines, four digits. Temperature & time or temperature & set temperature.
Display Resolution	Temperature: 1°C/°F and 0.1°C/ °F Time: 1 second/ minute.
Accuracy	Temperature: ± 0.5% of full input range. Time: 1 second.
Control Mode	Temperature: PID, manual control, on-off, Time: timed PID, timed on-off, independent timer
Timer Mode	Single delay, double delay, count up, count down
Timer Range	1 - 9999 seconds or minutes
Anti-Short Cycle Delay Timer Range	1 - 200 minutes
Control Output	Relay output: N.O. contacts. 10 A at 120 VAC, 10 A at 240 VAC, 10 A at 30 VDC
Alarm	Timer alarm, process high/low alarm, deviation high/low alarm
Alarm Output	Relay: 3 A at 240 VAC, 5 A at 120 VAC, or 3 A at 30 VDC
Power Supply	90 ~ 265 VAC, 50 ~ 60Hz
Dimension	1.89" x 1.89" x 4.25", or 48 x 48 x 108 mm (1/16 DIN)
Insertion Depth	From front panel: 3.95" or 100 mm
Panel Cutout	1.75" x 1.75" or 44.5 x 44.5 mm

3. Terminal Assignment

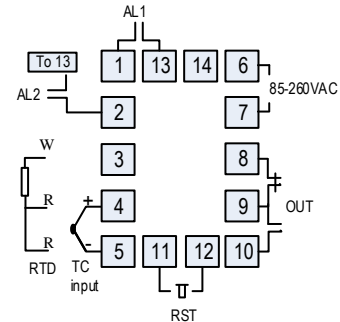

Figure 1. Wiring diagram

Note: Use a wire or a N.C. switch to jump pin 11 and 12 together to enable the timer.

3.1 Sensor Connection

Please refer to table 3 for the input sensor type (Sn) setting codes. The initial setting for input is for a type K thermocouple. Set Sn to the correct sensor code if another type of sensor is used.

3.1.1 Thermocouple

The thermocouple should be connected to terminals 4 and 5. Make sure that the polarity is correct. There are two commonly used color codes for the K type thermocouple. US color code uses yellow (positive) and red (negative). Imported DIN color code uses red (positive) and green/blue (negative). The temperature reading will decrease as temperature increases if the connection is reversed.

When using ungrounded thermocouple that is in touch with a large conductive subject, the electromagnetic field picked up by the sensor tip might be too large for the controller to handle, the temperature display will change erratically. In that case, connecting the shield of thermocouple to terminal 5 (circuit ground of the controller) might solve the problem. Another option is to connect the conductive subject to terminal 5.

3.1.2 RTD sensor

For a three-wire RTD with standard DIN color code, the two red wires should be connected to the terminals 4 and 5. The white wire should be connected to terminal 3. For a two-wire RTD, the wires should be connected to terminals 3 and 4. Jump a wire between terminals 4 and 5. Set controller input type Sn to Pt.

3.2 Power to the Controller

The power cables should be connected to terminals 6 and 7. Polarity does not matter. It can be powered by 120V or 240VAC power source. Neither a transformer nor jumper is needed to wire it up. For the sake of consistency with the wiring example described later, we suggest you connect the neutral wire to terminal 6 and hot to 7.

3.2.1 Timer Reset terminals

Terminals 11 and 12 are for connecting a reset switch. If you need to start the timer after controller is powered up, you should short these two terminals together with a jumper wire. To use the reset function, these terminals should be connected to a switch. Open the contact of the switch will rest the timer. Close the contact of the switch will start the timer. Some applications may need a N.O.

contact and other may need N.C. contact switch. Please see Fig. 7 and 9 for examples.

3.3 Control output connection

The relay output of SWA-2441B can be used to turn on an external contactor or a solenoid valve. This controller can also drive a small heater/load directly, if this load draws less than 10A/120V.

3.3.1 Connecting the load through a contactor: Assuming the controller is powered by 120V AC and the contactor has a 120V AC coil, jump a wire between terminals 9 and 7. Connect terminal 10 to one lead of the coil and terminal 6 to the other lead of the coil. Please see Figure 6 for example.

3.3.2 Connecting the heater (or cooler) directly from the internal relay. Assuming the controller and the load (heater or cooler) are powered by the same voltage. Jump a wire from terminal 9 to 7. Connect terminal 10 to the one lead of the load and terminal 6 to the other lead of the load. Please see Figure 7 for details.

3.4 For first time users without prior experience with PID controllers, the following notes may prevent you from making common mistakes.

3.4.1 Power to the relay output does not flow through terminal 6 and 7 of the controller. The controller consumes less than 2 watts of power, and it only provides a control signal to the relay. Therefore, wires in the 18 to 26 gauge range should be used for providing power to terminals 6 and 7. Thicker wires may be more difficult to install.

3.4.2 The control relay output and the alarm output are dry single pole switches. They do not provide power by itself. External power source is needed for wiring the relay outputs. See examples 6 or 7 for details.

3.4.3. The output of this controller is controlled by regulating the duration of on time for a fixed period of time. It is not controlled by regulating amplitude of the voltage or current. This is often referred as time proportional control. For example, if the cycle rate is set for 100 seconds, a 60% output means controller will switch on the power for 60 seconds and off for 40 seconds (60/100 = 60%). Almost all high-power control systems use time proportional control because amplitude proportional control is too expensive and inefficient.

4. Front Panel and Operation

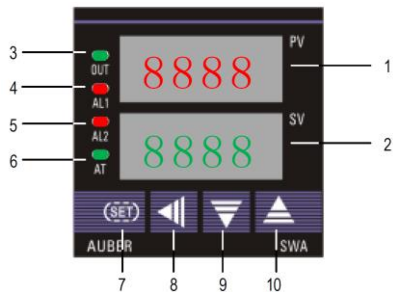

Figure 2. Front panel.

1. PV display: Indicates the sensor read out, or process value (PV).
2. SV display: Indicates the time when timer is used. If timer is deactivated, it indicates the set temperature (SV). In manual control mode, an "H" is displayed on the most left digit to indicate number is for percentage of output (%).
3. Output indicator: It is synchronized with control output (terminal 9 and 10), and the power to the load. When it is on, the heater (or cooler) is powered.
4. AL1 indicator: It is synchronized with alarm 1 relay (AL1). When timer is on, it works as the timer relay output indicator. When timer is deactivated, it lights when Alarm 1 condition meets.

5. AL2 indicator: It is synchronized with alarm 2 relay (AL2). It lights when Alarm 2 condition meets.
6. Auto-tune indicator: It lights up when auto-tune starts.
7. SET key: Press and hold this key for 3 seconds will enter the temperature control parameter setting mode. When the controller is in temperature, or timer parameter setting mode, press this key momentarily will lead the display to the next parameter.
8. Automatic/Manual function key/Data shift key ◀: press ◀ for 3 seconds to enter manual tuning mode. Press ◀ for 3 seconds again to exit.
9. Decrement key ▼: Decreases numeric value of the setting value. Press for 3 seconds to enter the timer setting mode.
10. Increment key ▲: Increases numeric value of the setting value. Press for 3 seconds to enter the temperature setting mode.

4.1 Display Modes

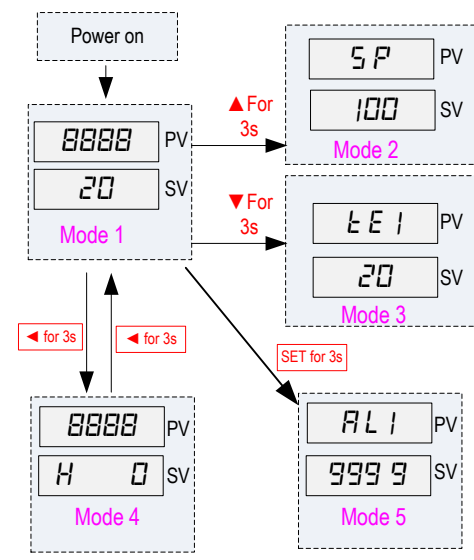

Figure 3. Display modes

Display mode 1: Normal operation display.

PV is the abbreviation for Process Value. SV is the abbreviation for Set Value. When the power is turned on, the upper display window shows the measured temperature value. If the timer is used, the lower window shows set timer value. When timer starts, it shows the time as it counts up or down. If the timer is disabled (INT = 0), the lower display shows the set temperature.

Display mode 2: Changing temperature set value (SV)

Press the ▲ key for 3 seconds, and then release it. The decimal point on the lower right corner will start to flash. Press the ▼ or ▲ key to change SV until the desired value is displayed. If the change of SV is large, press the ◀ key to move the flashing decimal point to the desired digit that needs to be changed. Then press the ▼ or ▲ key to start changing SV from that digit. The decimal point will stop flashing after no key is pressed for 3 seconds. The changed SV will be automatically registered without pressing the SET key.

Display mode 3: Timer parameter set up.

Press the ▼ key for 3 seconds to change the display status into timer parameter setting mode. The upper display window shows the timer parameter symbol to be changed, the lower display shows its value. Press the ◀, ▼ or ▲ to change the setting. Then, press SET to go to next parameter. If no key is pressed for 10 seconds, the display will return to mode 1 automatically. The change of value will take effect without the need for pressing the SET key. See 4.14 to 4.16 for more details.

Display mode 4: Manual mode.

Press the ◀ key for 3 seconds to enter the manual mode. In this mode, the lower display has an H on the most left. The number on the right is the percentage of power output. Press the ▼ or ▲ to adjust the power. Press the ◀ key for 3 seconds again to exit this mode. For more details, please see 4.3.

Display mode 5: Temperature control parameter setting.

Press the SET key for 3 seconds to enter the temperature control parameter setting mode. The upper display window shows the parameter symbol to be changed, the lower display shows its value. Press ◀, ▼ or ▲ to change the setting. Then, press SET to go to next parameter. If no key is pressed for 10 seconds, the display will return to mode 1 automatically. The change of value will take effect without the need for pressing the SET key. Figure 4 shows the flow chart of the parameters.

Note: If the controller is locked (see 4.13), only limited parameters (or no parameters) can be changed.

4.2 Parameter Name, Range and Initial Setting

See Table 2 and Figure 4 for parameter table and flow chart.

4.2.1 Alarm parameters

This controller has two alarm outputs: Alarm 1 (AL1, NO relay) and Alarm 2 (AL2, NO relay). Two red alarm indicators are located on the front panel: AL1 and AL2. Alarm 1 and AL1 indicator are synchronized. Alarm 2 and AL2 indicator are synchronized. When the AL1 (AL2) indicator is ON, alarm 1 (alarm 2) relay pulls in. When the AL1 (AL2) indicator is OFF, alarm 1 (alarm 2) relay drops off.

Each alarm is set by three parameters: ALP, AL and Hy. ALP1, AL1 and Hy1 are for Alarm 1. ALP2, AL2 and Hy2 are for Alarm 2. Alarm 1 can be set as either temperature alarm (ALP1 = 1 ~ 4) or timer alarm/output (ALP1 = 0). Alarm 2 can only be used for temperature alarm (ALP2 = 1 ~ 4). See ALP definition below.

ALP defines the type of alarm.

ALP = 0, timer alarm/output (alarm 1 only)

ALP = 1, high limit temperature alarm.

ALP = 2; low limit temperature alarm.

ALP = 3; deviation high temperature alarm.

ALP = 4, deviation low temperature alarm.

Note: When ALP1 is set to 0 (for timer output), parameter AL1 and Hy1 are not in use. Only ALP1 can be set to 0. ALP2 = 0 is not functional for SWA-2441B.

AL is for the alarm temperature setting. When alarm is set for high/low limit alarm, its value is the temperature that alarm will turn on. When alarm is set for high/low deviation alarm, its value indicates that the alarm will turn on when temperature is deviated AL degree from the set temperature (SV). Note: when alarm is set to deviation alarm (ALP1 / ALP2 is set to either 3 or 4), AL1 / AL2 can only be set to 100 as maximum.

Hy is the hysteresis band of temperature alarm. In heating mode, for high limit or deviation high alarm mode, the alarm will turn off when the temperature is Hy degree below alarm on setting; for low limit and deviation low alarm mode, the alarm will turn off when temperature is Hy degree above the alarm on setting.

Example 1: ALP1 = 1 (high limit alarm), AL1 = 250, and Hy1 = 5. In this case, alarm 1 will turn on when temperature goes above 250 degrees (AL1) and turn off when temperature drop to 245 degrees (AL1-Hy1).

Example 2: SV = 200, ALP1 = 4 (deviation low alarm), AL1 = 10, and Hy1 = 5. In this case, alarm 1 will turn on when temperature drop to 190(SV-AL1) and turn off when temperature goes up to 195 (SV-AL1+Hy1).

4.2.2 Hysteresis Band “Hy”

The Hysteresis Band parameter Hy is also referred as Dead Band, or Differential. It permits protection of the on/off control from high switching frequency caused by process input fluctuation. Hysteresis Band parameter is used for on/off control, as well as the on/off control at auto tuning. For example: When controller is set for on/off heating control mode, the output will turn off when temperature goes above SV+ Hy and on again when it drops to below SV-Hy.

Table 2. System parameters.

Mode 2: Press ▲ key for 3 seconds then release					
Code	Sign	Description	Setting Range	Initial Setting	Remark
SP	SP	Set Value	Decided by DIL, DIH	100	
Mode 5: Press SET key for 3 seconds then release					
AL1	AL1	Alarm 1 setting	-1999 ~ +9999 °C or °F	999.9	4.2.1
AL2	AL2	Alarm 2 setting	-1999 ~ +9999 °C or °F	0.0	
SC	SC	Input offset	-20 ~ 20	0.0	4.10
P	P	Proportional Constant	0.1 ~ 200.0	15.0	4.3.1
I	I	Integral time	0 ~ 2000	240	
D	D	Derivative time / delay time	0 ~ 200	30	
At	At	Auto-tune	On/off	Off	4.2.3
t	t	Cycle time	2 ~ 120	10	4.4
Hy	Hy	Hysteresis band	0.1 ~ 100.0	1.0	4.2.2
Hy1	Hy1	Alarm 1 hysteresis band	0.1 ~ 100.0	1.0	4.2.1
Hy2	Hy2	Alarm 2 hysteresis band	0.1 ~ 100.0	1.0	
dP	dP	Decimal point position	0 or 1	1	4.6
ALP1	ALP1	Alarm 1 definition	0 ~ 4	0	4.2.1
ALP2	ALP2	Alarm 2 definition	0 ~ 4	1	
COOL	COOL	Cooling control	On/Off	Off	4.10
outH	outH	Output high limit	0 ~ 100%	100	4.12
Lock	Lock	Configuration privilege	0 ~ 50	0	4.13
Sn	Sn	Input type	See Table 3	K	4.5
OPA	OPA	Output Mode	0	0	4.9
dIL	DIL	Input low limit	-1999 ~ DIH	0.0	4.7
dIH	DIH	Input high limit	dIL ~ 9999	999.9	
CF	CF	Display unit	C, F	C	4.11
Mode 3: Press ▼ key for 3 seconds and release					
TE1	TE1	Timer 1	0 ~ 9999	10	4.14
TE2	TE2	Timer 2	0 ~ 9999	0	
UPT	UPT	Timer unit and timer mode	0 ~ 3	0	4.15
INT	INT	Timer control mode	0 ~ 8	1	4.16

4.2.3 At (Auto-tuning)

The auto-tuning function (also called self-tuning) can automatically optimize the PID parameters for the system. The auto-tuning function will use the on/off mode to heat up the system until it passes the set point. Then let it cool down. It will repeat this about three times. Based on the response time of the system, the built-in artificial intelligence program will calculate and set the PID parameters for the controller. If your system has a very slow response, the auto tuning could take a long time.

To activate auto-tuning, enter the parameter setting mode, set At = ON. The “AT” LED on the left lower corner of the controller will light up. Auto-tune will finish when the AT LED turns off. The newly calculated PID parameters are set

and used for the system. Please note that auto-tuning is only for PID control mode. There is no need for auto-tune when using ON/OFF mode (when P = 0). To stop the auto-tuning, enter the parameter setting mode, set At = OFF. Then, the previous PID parameters values are resumed.

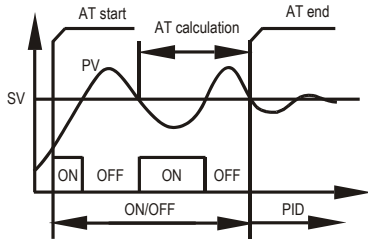

Figure 5. Auto tuning

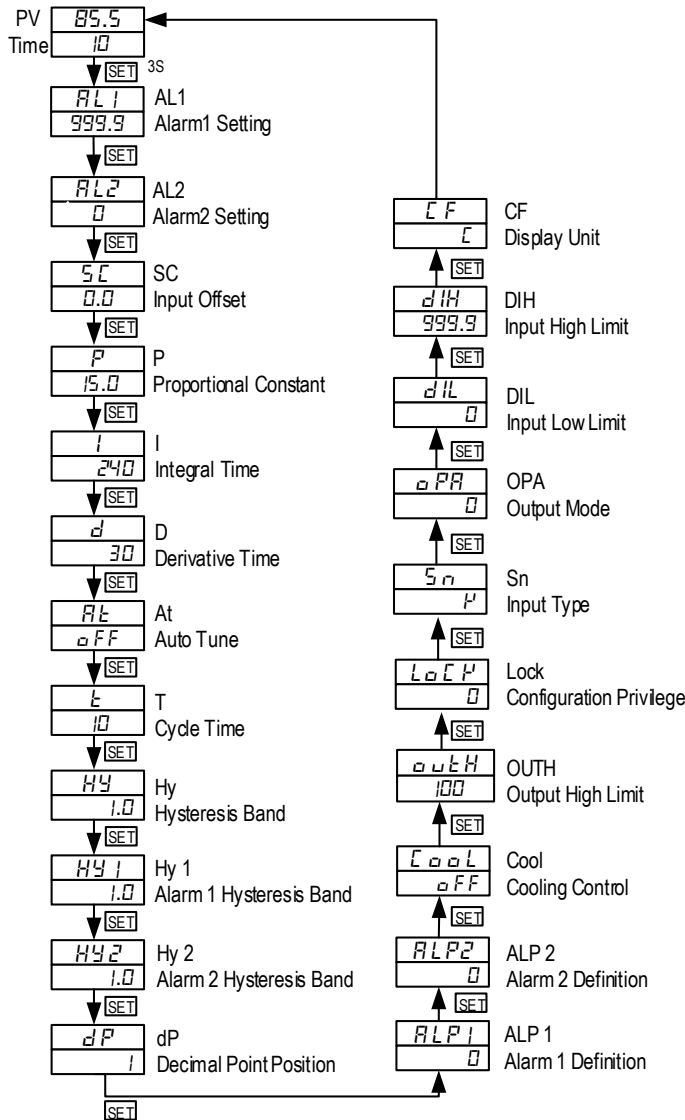

Figure 4. System setup flow chart.

4.3 Control action explanations

4.3.1 PID

The values of the P, I, and D parameters are critical for good response time, accuracy and stability of the system. Using the Auto-Tune function to automatically determine these parameters is recommended for the first time user. If the auto tuning result is not satisfactory, you can manually fine-tune the PID constants for improved performance.

Proportional Constant (P): P is also called the proportional band. Its unit is the degree of temperature. For example, P = 50 means the proportional band is 50 degrees. Assuming the set temperature SV = 200. When integral, I, and derivative, d, actions are removed - the controller output power will change from 100% to 0% when temperature increases from 150 to 200 °C. The smaller the P value is, the stronger action will be for the same temperature difference between SV and PV. **Please note: for on/off control mode, P is set to 0.**

Integral time (I): Brings the system up to the set value by adding to the output that is proportional to how far the process value (PV) is from the set value (SV) and how long it has been there. When I decreases, the response speed is faster but the system is less stable. When I increases, the response speed is slower, but the system is more stable. When I = 0, the integration is turned off. It becomes to a PD controller that is useful for very slow system.

Derivative time (d): Responds to the rate of PV change, so that the controller can compensate in advance before |SV-PV| gets too big. A larger number increases its action. Setting d-value too small or too large would decrease system stability, causing oscillation or even non-convergence. Normally, d is set to 1/4 of the I value. However, when the controller is in on/off mode (P = 0) and cooling control is turned on, d means Delay Timer of the Anti-Short Cycle Delay (Asd) function. The delay time ranges from 1-200 minutes. (See 4.3.3 for details).

4.3.2 On/off control mode

It is necessary for inductive loads such as motors, compressors, or solenoid valves that do not like to take pulsed power. It works like a mechanical thermostat. When the temperature passes the SV+Hy, the heater will turn off. When the temperature drops back to SV-Hy, the heater will turn on again. (In cooling mode, the cooler turns on when temperature passes SV+Hy, and turns off when temperature drops back to SV-Hy). **To use the on/off mode, set P = 0 and Hy to the desired band.** Then I and D parameters are not used when controller is in heating mode. It can be left at any value. In the cooling mode, the D value is used for Anti-Short Delay time. Its value is in minutes (See 4.3.3 for details).

4.3.3 Cooling control

When controller is used for cooling control and load is a compressor, it should not turn on the compressor when its refrigerant is at high pressure (just after turned off). Otherwise, the compressor can be damaged in short time. Two methods are commonly used to prevent the rapid cycling of the compressor. One is to use on/off control mode (instead of the PID control mode) with wide enough hysteresis band, and long cycle rate. The other is to use the Anti-Short Cycle Delay (ASd) function. ASd establishes the minimum time that the N.O. contacts remain open (after reaching cutout) before closing again. The delay overrides any Load Demand and does not allow the N.O. contacts to close until the set time-delay value has elapsed. ASd gives time to release the refrigerant pressure through evaporator. This controller allows the user to use both methods to protect the compressor. You should set the P = 0 for on/off mode. The cycle rate should be set for 20 second or longer. The D is typically set to 4- 6 (minutes).

4.3.4 Manual mode

Manual mode allows the user to control the output as a percentage of the total heater power. It is like a dial on a stove. The output is independent of the temperature sensor reading. One application example is controlling the strength of boiling during beer brewing. You can use the manual mode to control the boiling so that it will not boil over to make a mess. The manual mode can be switched from PID mode but not from on/off mode. This controller offers a "bumpless" switch from the PID to manual mode. If the controller outputs 75% of power at PID mode, the controller will stay at 75% when it is switched to the manual mode, until it is adjusted manually. See Figure 3 for how to switch the display mode. **To activate the manual control,** pressing the ◀ key for 3 seconds or until the bottom display shows H at the most left digit. The H indicating the controller is in manual mode. The number at the right is the percentage of output. Press the ▼ or ▲ key to adjust the power. To switch back to PID mode, pressing the ◀ key for 3 seconds or until the H disappeared.

4.4 Cycle time “t”

It is the time period (in seconds) that the controller uses to calculate its output. e.g. When t = 2, if the controller decides output should be 10%, the heater will be on 0.2 second and off 1.8 seconds for every 2 seconds. Smaller t values result in more precision control. For relay or contactor output, it should be set longer to prevent contacts from wearing out too soon. Normally it is set to 20 ~ 40 seconds.

Please note, cycle time t parameter is not used under ON/OFF mode (P = 0).

4.5 Input sensor type for “Sn”

Table 3. Code for Sn and its range.

Sn Code	Input Device	Display Range (°C)	Display Range (°F)
Cu50	Cu50 (RTD)	-49 ~ 160	-56 ~ 302
Pt100	Pt100 (RTD)	-199 ~ 610	-198 ~ 1111
K	K (thermocouple)	-30 ~ 1300	-20 ~ 2370
E	E (thermocouple)	-29 ~ 719	-20 ~ 1292
J	J (thermocouple)	-29 ~ 905	-20 ~ 1651
T	T (thermocouple)	-198 ~ 400	-190 ~ 750
S	S (thermocouple)	-29 ~ 1619	-20 ~ 2912
0 ~ 5	0 ~ 5V (0 ~ 10mA)	Not available for this model.	
1 ~ 5	1 ~ 5V (4 ~ 20mA)		

4.6 Decimal point setting “dP”

In case of thermocouple or RTD input, dP is used to define temperature display resolution.

When dP = 0, temperature display resolution is 1° (C or F).

When dP = 1, temperature display resolution is 0.1° (C or F). The temperature will be displayed at the resolution of 0.1° for input below 1000° and 1° for input over 1000° (C or F).

4.7 Limiting the control range, “DIL” and “DIH”

1) For temperature sensor input, the “DIL” and “DIH” define the set value range. DIL is the low limit, and DIH is the high limit. Sometimes, you may want to limit the temperature setting range so that the operator cannot set a very high temperature by accident. For example, if you set the DIL = 100 and DIH = 130, operator will only be able to set the temperature between 100 and 130.

2) For linear input devices, “DIL” and “DIH” are used to define the display span. For example, if the input is 0 - 5V. DIL is the value to be displayed at 0V and DIH is the value at 5V.

4.8 Input offset “SC”

SC is used to set an input offset to compensate the error produced by the sensor or input signal itself. For example, if the controller displays 5°C when probe is in ice/water mixture, setting Pb = -5, will make the controller display 0°C.

4.9 Output definition OPA

This parameter should be kept at zero for this model.

4.10 Heating, and Cooling Mode Selection “COOL”

When COOL = ON, the controller is set for cooling control.
When COOL = OFF, the controller is set for heating control.

4.11 Temperature Unit Selection, Celsius or Fahrenheit, “C, F”

This parameter sets temperature units, C for Celsius, F for Fahrenheit. When it is for current or voltage input, this parameter is voided.

4.12 Output range high limit “OUTH”

OUTH allows you set the output range high limit.

OUTH can be used when you have an overpowered heater to control a small subject. For example, if you set the OUTH = 50, the 5000W heater will be used as 2500W heater (50%) even when the PID wants to send 100% output.

4.13 Lock up the settings, parameter “LOCK”

To prevent the operator from changing the settings by accident, you can lock the parameter settings after initial setup. Table 4 shows the privileges associated with each lock code.

Table 4. LOCK parameter.

LOCK value	SV Adjustment	Other Parameters
0	Yes	Yes
1	Yes	Locked
2 and up to 50	No	Locked

Note: to limit the control temperature range instead of completely locking it, please refer to section 4.7.

4.14 Set Time for Timer “TE1” and “TE2”

“TE1” is for setting value for the timer. Press ▼ for 3 seconds and change the value directly.

“TE2” is for setting time of timer 2, it is only valid for dual timer working mode.

4.15 Time Unit and Timer Counting Mode “UPT”

UPT = 0, timer counting down in seconds.

UPT = 1, timer counting down in minutes.

UPT = 2, timer counting up in seconds.

UPT = 3, timer counting up in minutes.

4.16 Timer control mode “INT” *

INT = 0. **The timer is disabled.** The controller functions as a regular dual display controller. The lower display shows the set temperature instead of time.
INT = 1. The timer starts after the temperature reaches set point. When set time reaches, controller’s output stops and timer relay pulls in (turns on). It can be connected to a buzzer to warn the operator.

INT = 2. The timer starts after the temperature reaches set point. When set time reached, relay pulls in. The controller’s output will continue to be on.

INT = 3. The timer starts after the temperature reaches set point. When set time reaches, controller’s output stops. Relay pulls in when timer starts and drops out when it reaches the set time.

INT = 4. Timer function is independent of temperature controller. After powered up (or reset), timer starts. The relay will pull in (close) when it reaches the set time.

INT = 5. Timer function is independent of temperature controller. After powered up (or reset), timer starts and the relay pulls in (close). It will drop out (open) when it reaches the set time.

INT = 6. Timer function is independent of temperature controller. After powered up (or reset), the relay drops out (open) for preset time TE1, then pulls in for preset time TE2. This process cycles (dual timer cycling mode).

INT = 7. Timer function is independent of temperature controller. After powered up (or reset), the relay drops out (open) for preset time TE1, then pulls in for preset time TE2. The relay will remain drop out (open) until reset. After reset, the relay will keep open for preset time TE1 then pulls in for preset time TE2 again (dual timer no cycling mode).

INT = 8. Timer function is independent of temperature controller. After powered up (or reset), the relay pulls in for preset time TE1 then drops out (open) for preset time TE2. This process cycles (dual timer cycling mode).

Note *:

i). When INT value is greater than 0, timer is enabled. The bottom of the display is for time. In order to let the timer controls the Alarm 1 (AL1), ALP1 should be set to 0.

ii). Terminal 11 and 12 must be jumped together to enable the timer. Timer can be started either at powering up of the controller if terminal 11 and 12 are shorted together, or at shorting terminal 11 and 12 if they are not shorted together.

iii) While the timer is running, it can be reset by pressing a reset switch (a normally closed momentary switch) that is connected between terminal 11 and 12.

iv) When INT is set to 1, 2 or 3, after reset, timer starts counting again if temperature reaches SV. If the temperature is lower than SV in heating mode (or higher than SV in cooling mode), timer won't restart until temperature reaches SV again.

5. Application Examples

A. Powder Coating Oven (Contactor)

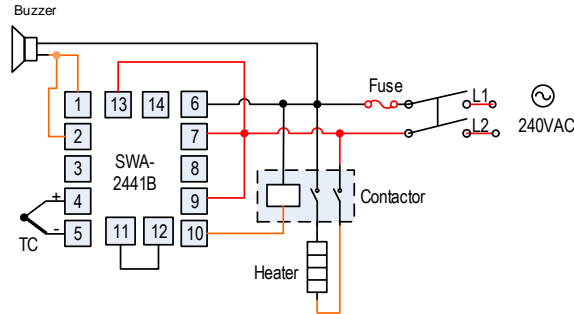

Figure 6. Typical wiring set up for powder coating oven.

A powder coating oven needs to heat up to 375 °F. Hold the temperature for 20 minutes. Then, turn off the heater and turn on the buzzer. The application needs a controller SWA-2441B, a 40A/240V contactor, a thermocouple and a buzzer with a 220VAC power source. Using alarm 1 as timer alarm, alarm 2 as high temperature alarm.

Example settings: SV = 375°F, ALP1 = 0, ALP2 = 1, AL2 = 400°F, UPT = 1, TE1 = 20, INT = 1.

B. Heat press for heat transfer printing

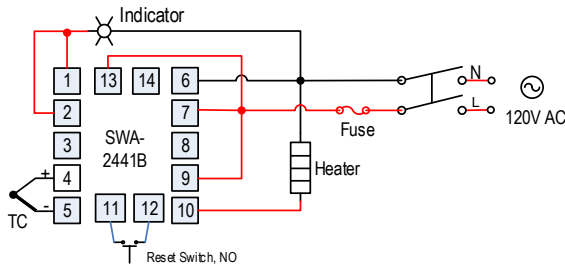

Figure 7. Typical wiring for a heat press.

When the press is down, it closes the micro switch. The heater will heat to 300°F for 2 minutes and then stop. Alarm light turns on. When reading temperature is over 320°F, alarm light turns on as well.

Example settings: SV = 300°F, ALP1 = 0, ALP2 = 1, AL2 = 320°F, UPT = 1, TE1 = 2, INT = 1. This example assumes the heater is less than 1000 W. For larger heater, an external relay is needed.

6. Troubleshooting Tips

6.1 Timer won't start

Check the connection between terminal 11 and 12. These two terminals must be jumped together to enable the timer. A momentary NC switch on pin 11 and 12 can serve as a timer-reset switch.

6.2 No heating

The OUT LED is synchronized with output relay. If there is no heat when it is supposed to, check the OUT first. If it is not lit, the controller parameter setting is wrong. If it is on, check external switching device (if the relay is pulled-in, or

the SSR's red LED is on). If the external switching device is on, then the problem is either the external switching device output, its wiring, or the heater. If the external switching device is not on, then the problem is either the controller output, or the external switch device.

6.3 Poor accuracy

Please make sure calibration is done by immersing the probe in liquid. Comparing with reference in air is not recommended because response time of sensor depends on its mass. Some of our sensor has response time >10 minutes in the air. When the error is larger than 5 °F, the most common problem is improper connection between the thermocouple and the controller. The thermocouple needs to be connected directly to the controller unless thermocouple connector and extension wire is used. Copper wire or thermocouple extension wire with wrong polarity connected on the thermocouple will cause the reading drift more than 5 °F.

6.4 Display "HH" or "LL"

This is an input error message. The possible reasons are: the sensor is not connected or not connected correctly; the sensor input setting is wrong; or the sensor is defective. In this case, the instrument terminates its control function automatically. If this happens when using thermocouple sensor, you can short terminal 4 and 5 with a copper wire or paper clip. If the display shows ambient temperature, the thermocouple is defective. If it still displays "HH", check the input setting, Sn, to make sure it is set to the right thermocouple type. If the Sn setting is correct, the controller is defective. For RTD sensors, check the input setting first because most controllers are shipped with the input set for thermocouples. Then check the wiring. The two red wires should be connected to terminals 4 and 5. The white wire should be connected to terminal 3.

6.5 Cannot change set temperature

Please check parameter dIH and dIL. These two parameters limit the set temperature range. If you set dIH and dIL at the same value (like 100), the set temperature (SP) can only be set as 100, and user cannot adjust it.

Auber Instruments

5755 North Point Parkway, Suite 99

Alpharetta, GA 30022, USA

www.auberins.com

Copyright © 2023 Auber Instruments Inc. All rights reserved. No part of this datasheet shall be copied, reproduced, or transmitted in any way without the prior, written consent of Auber Instruments. Auber Instruments retains the exclusive rights to all information included in this document.