

Instruction Manual

# SYL-53X2P(A) USB PID Controller Quick Guide

Version 1.8 (Jul, 2023)

## ⚠ Caution

- This controller is intended to control equipment under normal operating conditions. Failure or malfunction of the controller may lead to abnormal operating conditions, which result in personal injury or damage to the equipment or other property. Devices (limit or safety controls) or systems (alarm or supervisory) intended to warn of or protect against failure or malfunction of the controller must be incorporated into and maintained as part of the control system.
- This controller carries a 90-day warranty. This warranty is limited to the controller only.

### 1. Terminal wiring

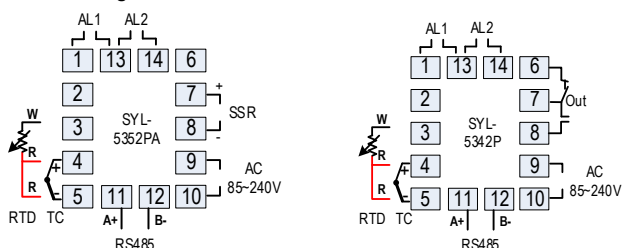
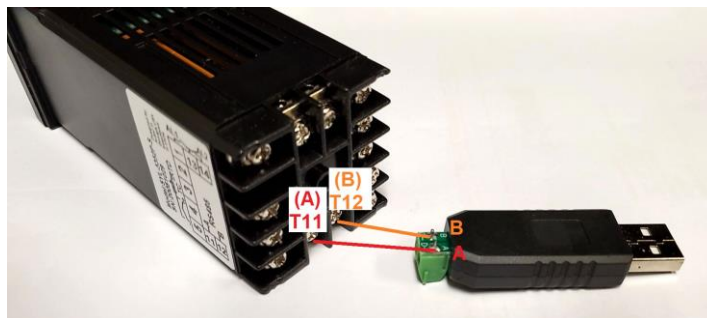
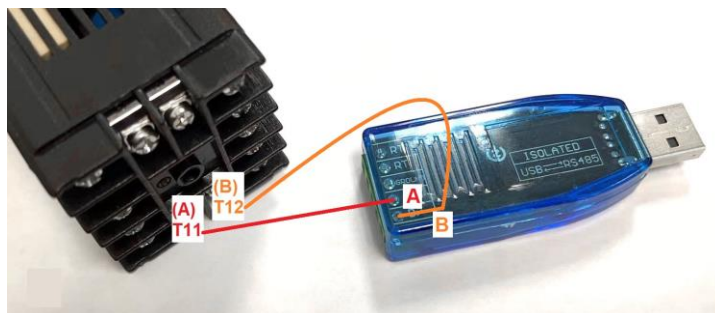

Figure 1. Wiring terminals of SYL-5352PA & SYL-5342PA.

### 2. USB adapter wiring (IMPORTANT!)



Locate the pin A and B on the back of the USB adapter.



Use the included 2-lead cable to **connect terminal 11 (A) on the PID to A mark on USB adapter**, and **connect terminal 12 (B) on the PID to B mark on USB adapter**. It is recommended to use **red wire** to connect between two A pins, and use **black wire** to connect between two B pins.

**Please note, USB cable on terminal 11 & 12 must be secured and isolated from the power input cable on terminal 9 & 10. Otherwise high voltage AC power from the power input cable may damage your USB adapter and/or your computer.**

### 3. Operation tips:

**Program Start/Resume:** Press and hold UP key for 2s, A-M indicator will be solid ON.

**Program HOLD:** Press and hold UP key for 2s, display will flash HOLD and A-M indicator will be flashing.

**Program STOP:** Press and hold SET and A/M key together for 3s, you will see SEC on the top. Press SET key 4 times momentarily, and you will see RUN on the top. Use UP and DOWN keys to change its value to 1. Press SET key again to confirm. Leave the PID for couple seconds and it will exit automatically.

**Program STOP and go back to step 1 (SYL-5342PA & SYL-5352PA or newer models):** Press and hold DOWN arrow key for about 3s, the lower display window will show "S t o P". The program is stopped and jumped back to step 1. **Program STOP and go back to step 1:** Press and hold SET and A/M key together for 3s, to enter menu, then change both RUN and Pro back to 1.

### 4. Recommended settings:

This controller has two layers of menus. One menu is for parameters, another menu for step programming and step control parameters.

Press and hold SET key for 3s to enter parameter setting menu. Then press SET key momentarily to confirm and go to next parameter. See all its parameters in its complete manual below. Here are recommended changes on the setting:

**P = 100:** By default, P=0 for ON/OFF mode (like thermostat). For PID mode, please change P parameter to 100 (recommended value). If you don't have good control result, please run auto-tune.

**T = 2 or 20:** T is output cycle time. For SSR output controller (SYL-5352PA), please change T to 2s. For relay output (SYL-5342PA), please change T to 20s.

**dP = 0:** dP is for display decimal point. If you don't need 0.1 degree accuracy, change dP to 0 and it will show integral number only.

**CF = F:** Change temperature display unit to Fahrenheit. Default is Celsius.

**PuH = 2500:** PuH decides the maximum display temp. Default is 1300 degree, may not good for high temp application like kiln.

Press and hold SET key and A/M key together for 3s to enter step programming setting. Here are recommended changes on the setting:

**LOOP = 0:** By default, program looping is enabled. To disable program looping, change LOOP to 0.

**RUN = 3:** By default, this controller is under single step mode. To use ramp soak feature, set RUN to 3.

**5. Wiring and programming example: powder coating/heat treatment oven**

An oven needs to heat up to 375°F from ambient in 5 minutes. Then hold the temperature for 20 minutes. After that, pull in the AL2 relay for 2 minutes. If the temperature is higher than 450°F, trigger the AL1 relay. This application needs a controller, a relay/SSR, a thermocouple and two buzzers with a 12V DC power source.

**a. Wiring**

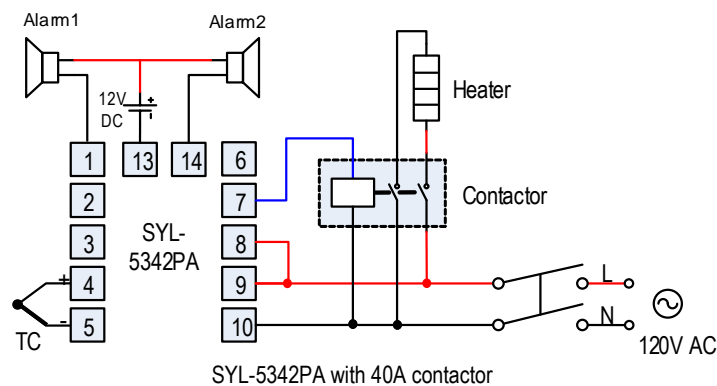
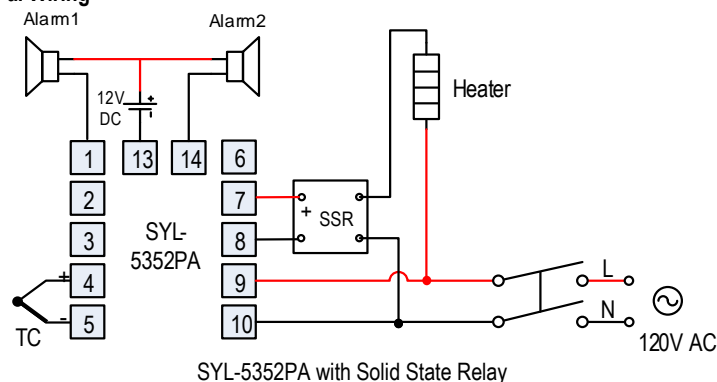

**b. Parameter setting and program**

SSb = 5. Safety start band is set to 5 degree.  
 LOOP = 0. Program automatically looping is disabled.  
 ALP = 1. Alarm 1 is set to absolute high alarm.  
 AL1 = 450. Alarm 1 will be activated when reading temperature is over 450  
 AL2 = 120. Program ending alarm is set to 120s. Once all the steps have been executed, alarm 2 will be activated for 120s.  
 T = 2 or 20. Set cycle time to 2s for SYL-5352PA, and set 20s for SYL-5342PA.

The program:

**r01 = 2000, t01 = 0, C01 = 80.** Initial step. r01 must be 2000. C01(80F) is ambient temperature.

**r02 = 5, t02 = 20, C02 = 375.** Ramp up from 80 to 375 in 5 minutes, then soak at 375 for 20 minutes.

**r03 = 0, t03 = 0, C03 = 0.** End of the program. Change all three parameters to 0.

Quick explanation: Cxx is end temperature of that step. rxx is the ramp step timer, txx is the soak step timer. Every step, controller will run ramp up step at first, then run soak step.

**6. Windows Communication software notes:**

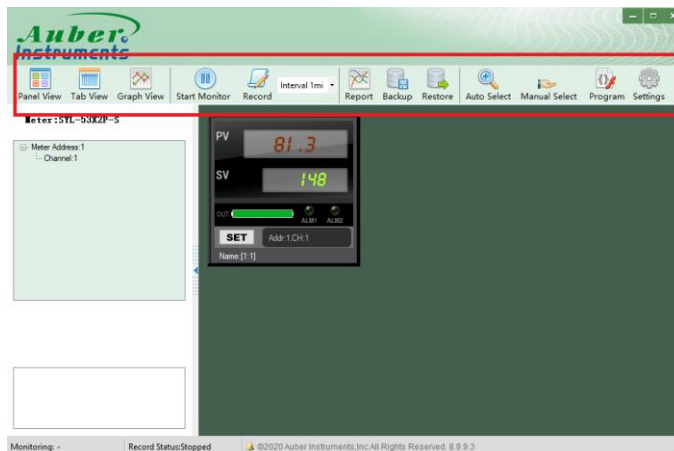

- 1). Default login password is: admin
- 2). After you login, for first timer user, please click "Auto Select" on the right top of the screen. Click "Detect" button on the right, then this software will automatically scan your connected PID controller. Once finished, you will see SYL-53X2P-S is detected (if you PID model is SYL-5342P-S/SYL-5342PA/SYL-5352P-S/SYL-5352PA). Then click "Apply" button. If your software cannot detect this PID, please confirm your computer has the correct driver for this USB adapter (see note in the software zip file) and check the continuity between your adapter and your PID by using a multimeter.
- 3). You will see the screenshot information above under "Panel View" on the left top. Click SET button and you can change all the parameters. If you want to change multiple parameters, please click "Tab View" button on the top. Then right click the number showing on the right.
- 4). Click "Start monitor" on the top and you will see temperature chart under "Graph View".
- 5). Click "Record" on the top and you can use "Report" or "Backup" / "Restore" functions later.
- 6). To edit ramp soak profiles, click "Program" button on the right top.

**7. Manual & Download**

**Operation Manual (Full Version):**  
 SYL-5352PA:  
<https://bit.ly/5352pmanual>

**Operation Manual (Full Version):**  
 SYL-5342PA:  
<https://bit.ly/5342pmanual>

Or scan the following QR code by your smartphone:

Or scan the following QR code by your smartphone:

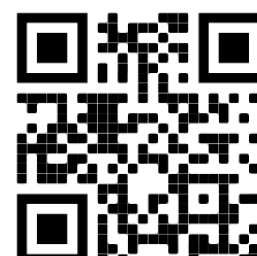
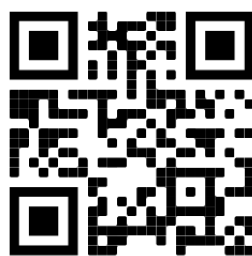

**Win Software Download Link:**  
<https://bit.ly/AuberPIDWin>

Or scan the following QR code by your smartphone:

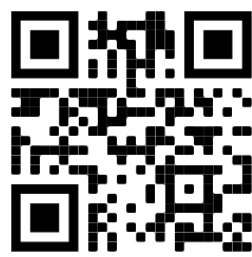

**Auber Instruments**  
 5755 North Point Parkway, Suite 99  
 Alpharetta, GA 30022  
[www.auberins.com](http://www.auberins.com)  
 Email: [info@auberins.com](mailto:info@auberins.com)

Copyright © 2023 Auber Instruments Inc.  
 All rights reserved.  
 No part of this manual shall be copied, reproduced, or transmitted in any way without the prior, written consent of Auber Instruments. Auber Instruments retains the exclusive rights to all information included in this document.